

THURSDAY, SEPTEMBER 14th • 10 AM LOCAL TIME

INDUSTRIAL AUCTION

Surplus To The Needs Of: PRESS-SEAL GASKET CORPORATION

**HUGE QUANTITY-
HIGH QUALITY
COPPER &
STAINLESS**

Charleston Auctions
433 Council Drive
Fort Wayne, IN 46825
1-260-373-0850
Toll Free: 1-877-301-9344
Fax: 1-260-373-0854



PRESS-SEAL
GASKET CORPORATION

Live Internet Bidding

BidSpotter.com[®]

COMPANY
LICENSE:
AC68900001

SALE LOCATION: 6935 LINCOLN PARKWAY, FORT WAYNE, INDIANA 46804

1996 HELISYS LOM 2030-H Rapid
Prototype Machine



1994 HELISYS LOM 2030 Rapid
Prototype Machine



BLISS 75 Ton
Stamping Press

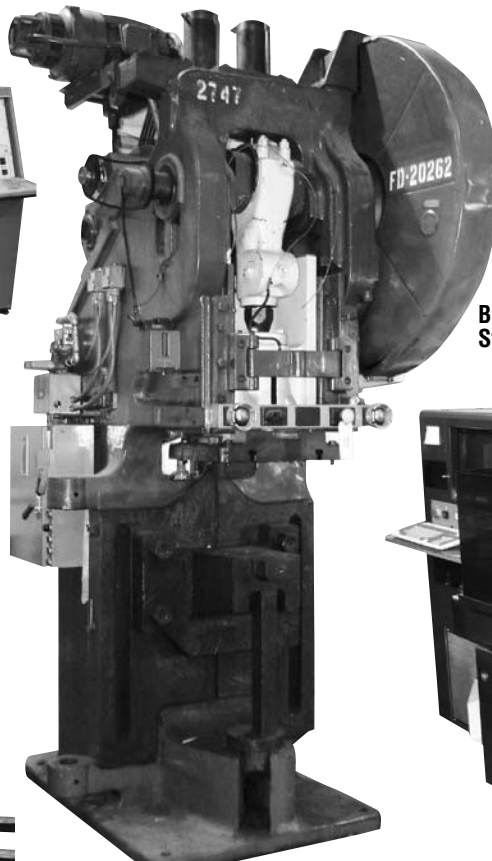

HYSTER
12,000 Lb.
Fork Lift



JAPAX Wire EDM



THURSDAY, SEPTEMBER 14th • 10 A.M. Local Time • PREVIEW INSPECTION: Wednesday, Sept. 13th, 9:00 A.M. – 5:00 P.M.





(1) of (2) HYSCO Hydraulic 4-Post Presses



BROWN & SHARPE "Micro-master" Surface Grinder



CINCINNATI Radial Arm Drill



FRENCH Hydraulic Press



HOLMES Hydraulic 4-Post Press



INGERSOLL RAND 30 HP Air Compressor



INGERSOLL RAND Air Dryer



Lg. Qty. Of 304 & 316 Stainless Steel Scrap (Not Blended)

PRESS & PRESS RELATED:

- BLISS No. 43 Stamping Press, Model 43, 75 Ton, Slide Adj. 3", Stroke 6", Shut Height on Bed 14", Air Clutch, S/N H52322
- PH HYDRAULICS 4-Post Down Acting Press, Model 4C-200P, 200 Ton, BTB = F-B 32", L-R 40", 36" x 36", Bolster, S/N 60054
- HOLMES 4-Post Up Acting Press, Between Tie Bars = F-B 17", L-R 32"
- (2) HYSCO Hydraulic Presses 4-Post Down Acting, Between Tie Bars = F-B 28", L-R 36", Hydraulic
- FRENCH Up Acting Straight Side Press, Hydraulic, 23" x 38" Day Light
- RELIABLE Rubber Mill, 12" Rolls, 3 Phase, 7 1/2 HP, Push Button Controls, S/N 2319
- DESMA KLOCKNER FERROMATIK, Automatic Rubber Splicing Machine, Type 956.040, w/ 87 Cubic Inch Stroke Volume, Vintage Contols (OFFSITE)

- CINCINNATI Radial Arm Drill, 5' Arm x 9" Column, 3 HP, S/N 1R3089
- MILWAUKEE Universal Milling Machine, Twin Spindle, 15" x 60" Table Size, S/N 1854-S-17-1402
- (2) MAGNAFLUX Machines, Model SB57, Single Phase, S/N 42038
- (3) VICKERS Central Hydraulic Systems w/ Control Panels (COMPLETE)
- CLAUSING Variable Speed Drill Press, Model 1781, 1/2" Chuck, 15" Model
- **Lg. Qty. Copper Wire, 304 Stainless Steel and 316 Stainless Scrap (Not Blended)**

MATERIAL HANDLING:

- 2000 HYSTER 12,000 Lb. Electric Fork Lift, Model E-120-XM, 60" Hydraulic Forks, Side Shift
- 2000 YALE 8,000 Lb. Electric Fork Lift, Model ERC-080, 48" Hydraulic Forks
- 1999 DAEWOO 4,000 Lb. Fork Lift, Model G 20 E-3, LP Gas, 48" Forks, Pneumatic Tires
- 1998 KOMATSU 4,000 Lb. Fork Lift, Model FG-20-12W, LP Gas, 2-Speed Transmission, Pneumatic Tires
- WEIGH-TRONIX Hydraulic Pallet Jack, Model WI-125, w/ Digital Scale & Printer, S/N 030818
- Lg. Qty. of Skate, Roller & Flex Conveyor, Multi Direction Roller Curves & Corners
- Various 24 & 36 Volt Battery Chargers

ELECTRICAL DISCHARGE MACHINES:

- 1994 LDMS JAPAX Wire EDM, Pendant Controls w/ Filters, Orion Chiller, 3 Phase, S/N 845-00-287

PROTOTYPE & MISC. EQUIPMENT:

- 1996 HELISYS LOM Rapid Prototype Machine, Model LOM-2030H, Produces: 3-D Models, Prototypes, Molds & Patterns, Single Phase, Pentium CPU, Chamber Heating Module, Material Size Up To 28", Material Thickness 0.003" to .008", S/N 2030-0211
- 1994 HELISYS LOM Rapid Prototype Machine, Model LOM-2030, Single Phase, Pentium CPU, Material Size Up To 28", Material Thickness 0.003" To .008", S/N 20300029
- WILLIS Gap Bed Lathe, Model CP1550, 7.5 HP, 2 1/2 Spindle Hole, 15" Swing, 50 BTC, Metric & Standard, Dro, 3 Phase, All Tooled Up, S/N 5742

SAWS:

- WELLSAW Vertical Band Saw, 20" Throat, 26' x 26' Tilt Table, Variable Speed, 3 Phase, 3 HP
- KALAMAZOO Automatic Power Hack Saw, Model H12B, Variable Speed Drive, Hydraulic Operating Lift, 1" Blade, 3 HP, 3 Phase, S/N H2856H2
- EVERETT 12" Abrasive Chop Saw, Built in Dust Collector



GRINDING MACHINES:

- MITSUI High Tec Surface Grinder, Model 2000 MH, 6" x 12" Magnetic Chuck, 3 Phase, S/N 94028074
- BROWN & SHARPE 818 Micromaster, Surface Grinder 8" x 18" Electro Magnetic Mounted To 8" x 18" Size Plate, S/N 523-81810-7435
- REID Surface Grinder, Max RPM-3600, 6" x 12" Magnetic Chuck Mounted To A 6" x 12" Sine Plate, S/N 18138M
- DELTA Tool Grinder, Variable Speed, 6" x 12" Magnetic Chuck
- Belt Sander, Model CT-13325, S/N 114484

PLANT SERVICING EQUIPMENT:

- (2) INGERSOLL RAND Horizontal 30 HP Air Compressors, Model 30T300 & 30TE30, S/N 775247 & 5863638
- 1986 INGERSOLL RAND Hydrogard Air Dryer, Model HG281-E5, 3 Phase, S/N 861HG0147
- Lg. Qty. Electrical To Include: Motors, Transformers, Control Boxes, Switch Boxes, Breaker Boxes
- CLARK Floor Scrubber, Model TB18, S/N 7947
- (3) LIEBERT CORPORATION Chiller Units w/ Precision Power Controls w/ roof units
- Over 40 Sections INTERLAKE Heavy Duty & Light Duty Pallet Racking, 36"D x 12' H x 12' Cross Beam
- Lg. Qty. Various Motors, Pumps, Electrical, Transformers, Controls & Relays
- (9) Various Ceiling Mount Hot Water Heaters
- INGERSOLL RAND Over Head Gantry System, 25'
- Lg. Qty. Wire Way/Auxiliary Gutter
- Lg. Qty. Cleaning Supplies Consisting of: Mops, Brooms, Shovels, Trash Cans, Mop Buckets & Wheelbarrows

Q.C. AND LAB EQUIPMENT:

- CP Lab Oven, Model 05015-58, Single Phase Tensometer Rheometer
- MONSANTO Rheometer 100, Model R-100, S/N 12A739T
- MONSANTO Tensometer, Model 110, S/N ST10-1021

OFFICE:

- Lg. Qty. Office Furniture Consisting of: Desks, File Cabinets, Chairs, Coat Trees, Tables, Tracing Cabinets, Microwaves & Various ALLIED-GARY Digital Touch Pad Safes
- Lg. Qty. Office Partitions, Steel Frame Doors, Wood Doors & Suspended Computer Floor



Light Duty Wide Belt Sander



MITSUI Surface Grinder



REID Surface Grinder



RELIABLE Rubber Mill



KALAMAZOO Automatic Power Hack Saw

IMPORTANT INFORMATION

SALE LOCATION: 6935 Lincoln Parkway, Fort Wayne, IN 46804

DATE & TIME: The Auction will begin promptly at 10:00 A.M. (EST) on Thursday, September 14th.

PREVIEW INSPECTION: The items will be available for advance inspection from 9:00 A.M. - 5:00 P.M. (EST) on Wednesday, September 13th.

TERMS OF SALE: A 10% Buyer's Premium will be charged on all purchases. A 13% Buyer's Premium will be charged if using Mastercard or Visa. For On-Line Auction Terms, please visit bidspotter.com. All bidders must register and provide proper identification. All items are sold "as is, where is" and must be paid for IN FULL, in CASH OR CHECK, accompanied by A LETTER FROM THE PAYOR'S BANK GUARANTEEING QUALIFIED PAYMENT TO CHARLESTON AUCTIONS for this sale.

REMOVAL: All rigging and moving companies must show proof of insurance. No items will be removed without proof of payment. Sale day removal from conclusion of sale until 6 PM. **Removal times will be from 9:00 A.M. to 5:00 P.M. Local Time, Friday the 15th and Monday the 18th.** Lots not paid for and/or removed within the time allotted may be resold at public or private sale without further notice, and any deficiency, together with all expenses and charge of resale, will be charged to the defaulting purchaser. Your stamped paid receipt must be shown to checkout supervision prior to removal. Although checkout supervision will be provided, the auction company and sellers are not liable for lost or stolen items purchased at the sale.

NOTE: While all information contained in this brochure and other advertising has been obtained from sources deemed reliable, neither the auction company, seller, nor publisher shall be liable for any errors or for the correctness of descriptions. All purchases are made "as is, where is" based entirely on the personal inspection and/or opinion of the purchaser and without warranty or guarantee of any kind. Statements made sale day take precedence over printed matter.



PH HYDRAULICS 4-Post Press



Over 10,000 Lbs. Of Copper Cable



433 Council Drive, Fort Wayne, IN 46825

PRSR
FIRST CLASS MAIL
U.S. Postage PAID
Fort Wayne, IN
Permit No. 650

Surplus To The Needs Of: PRESS-SEAL GASKET CORPORATION

Sale Location: 6935 Lincoln Parkway
Fort Wayne, Indiana 46804

THURSDAY, SEPTEMBER 14th
10 A.M. Local Time

Doors open at 8:00 A.M. on Sale Day
Preview Inspection: Wednesday, September 13th
9:00 A.M. – 5:00 P.M.

SEPTEMBER

SUN	MON	TUE	WED	THU	FRI	SAT
					1	2
3	4	5	6	7	8	9
10	11	12	13	14	15	16
17	18	19	20	21	22	23
24	25	26	27	28	29	30

AUCTION

Surplus To The Needs Of: PRESS-SEAL GASKET CORPORATION

Thursday, September 14th • 10 A.M. Local Time

LINCOLN PARKWAY, FORT WAYNE, IN

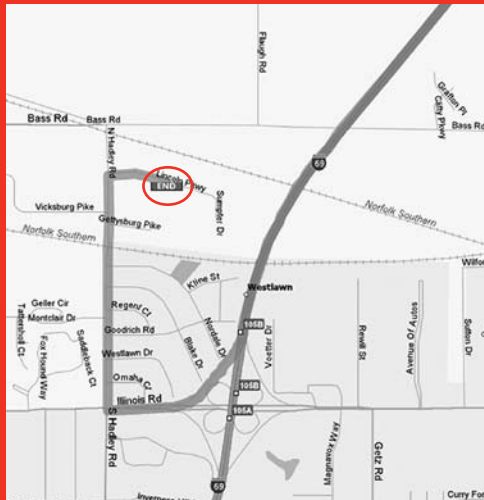

DRIVING DIRECTIONS

I-69 to Exit 105 (Hwy 14 exit) go West to Hadley Road (first stop light)
turn Right follow to Lincoln Parkway turn Right - Follow Auction Signs!

Sale Location: 6935 Lincoln Parkway, Fort Wayne, Indiana 46804

For additional directions: visit WWW.MAPQUEST.COM



PRESS-SEAL
GASKET CORPORATION

ROLLING STOCK

1999 DAEWOO 4,000 Lb.
Fork Lift



1998 KOMATSU 4,000 Lb.
Fork Lift



2000 YALE 8,000 Lb.
Electric Fork Lift

